

# Buggy Kart

- (F) Manuel d'instructions
- (GB) Owners Manual
- (D) Gebrauchsanweisung
- (I) Avvertenza per il montaggio e di utilizzazione
- (E) Instrucciones de montaje
- (P) Nota da montagem e da utilização
- (S) Bruksanvisning



BREVETÉ - PATENTED

- **Instructions de sécurité**
- **Instructions de montage**

*Attention : merci de lire et de suivre toutes les instructions avant d'utiliser ce produit.*

- **Important Safety Instructions**
- **Assembly Instructions**

*Caution : read, understand and follow all instructions before using this product.*

- **Sicherheitshinweise**
- **Montageanleitung**

*Bitte beachten Sie : Die Anweisungen vor der Benutzung des Produktes zu lesen und zu befolgen.*

- **Istruzioni di sicurezza**
- **Istruzioni di montaggio**

*Attenzione : leggere e seguire tutte le istruzioni prima di utilizzare questo prodotto.*

- **Instrucciones de seguridad importantes**
- **Instrucciones para el ensamblaje**

*Atención : siga fielmente todas las instrucciones antes de utilizar este producto.*

- **Instrução de segurança**
- **Instrução da montagem**

*Atenção :Agradecemos que leia e de seguir todas as instruções antes da utilização deste produto.*

- **Viktig säkerhets information**
- **Monterings anvisningar**

*Observera : läs, förstå och följ alla instruktioner innan du använder denna produkt.*

**GARDEN** Kart

 **CQFD**

# Important Safety Instructions

---

1. READ ALL INSTRUCTIONS CAREFULLY BEFORE USE.
2. Do not load dumping BUGGY KART with more than 1000 lbs (453 kg). Do not use the dumping features of the dumping BUGGY KART with more than 400 lbs (181 kg).
3. Do not allow children to use the BUGGY KART unsupervised. This dumping BUGGY KART is not a toy.
4. Always distribute payload evenly over the surface of the bed.
5. Do not load any items on the top edges of the plastic tray.
6. Do not operate or use on objects that can cause damage to the pneumatic tires or tubes. Do not inflate tires to more than 32 PSI (2,2 bar).
7. Save these instructions.

# Assembly Instructions

---

Your BUGGY KART requires assembly. Account for all parts and hardware before beginning assembly.

Tools required for assembly : standard screwdriver, philipps screwdriver and socket set (or two adjustable wrenches).

## Step 1

Assemble front bracket to front frame using M8X20 bolts (4 pcs), M8 lock nuts (4 pcs) and washers (4 pcs).

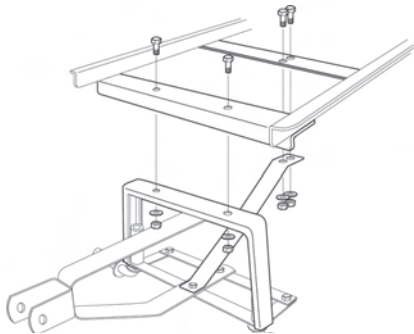

## Step 2

Assemble rear bracket to rear frame and tub using round head M8X30 bolts (4 pcs), M8 lock nuts (4 pcs), ID 8mm wide wing washers (8 pcs).

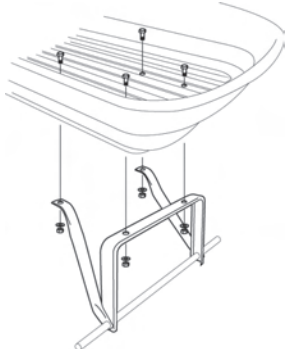

## Step 3

Assemble lock to tub using round head M8X20 bolts (4 pcs), M8 lock nuts (4 pcs), ID 8mm wide wing washers (8 pcs).

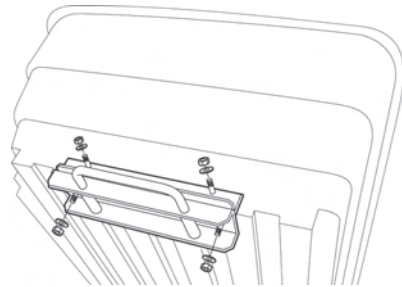

## Step 4

Place tub into its dump position. Remove shoulder bolts from rear. Take the front axle and frame and slide it over the back bracket where the bolts were just removed. Once aligned, reinsert shoulder bolts. The rear frame, and tub should now all be connected.

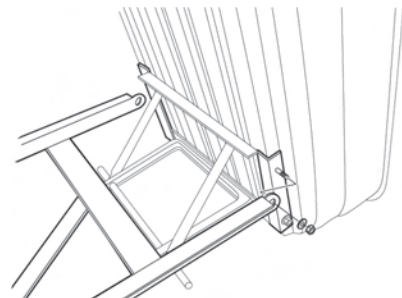

**Step 5**

Assemble the wheels using the M12 lock nuts (4 pcs), spacers (4 pcs) and washers (4 pcs).

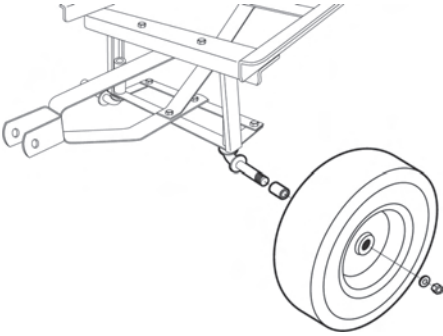
**Step 6**

Assemble the handle to the yoke using M8X60 bolt (1pc), M8 lock nut (1pc) and washer (1 pc).

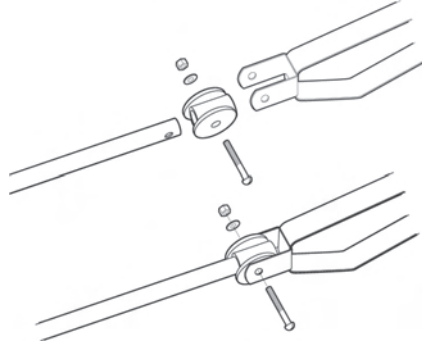

## Using the Dumping Feature

To operate the dumping feature, pull the dumping release handle outward to release the plastic bed from the locking mechanism. Lift up the release handle to rotate kart upward into the dumping position.

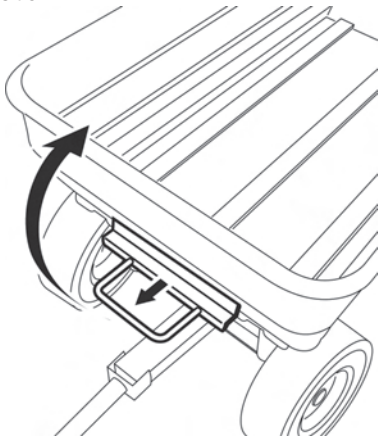

Rotate the plastic bed back down to the lowered position. Make sure the dumping release handle is locked into place when the kart is in the lowered position.

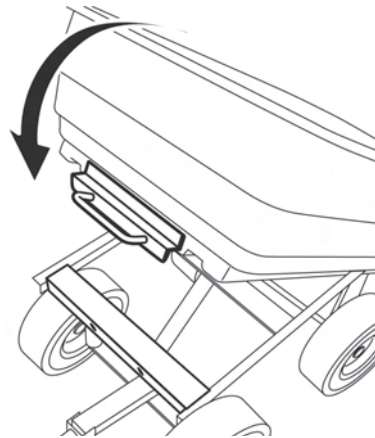

### ATTENTION

Do not exceed maximum capacity overall load capacity 1000 LBS. Maximum dumping load capacity 400 LBS.

# Buggy *Kart*



**GARDEN** *Kart*

 **CQFD**

Z.I. Route de Ravel - 69440 ST-LAURENT-D'AGNY - FRANCE